

CHAR-MASTER™

Hamburger-Chicken-Wings-Steak Flame Broiler



MODEL #7450

- 4 Burner
- Return-flow
- Single Meat Chain

Designed for high volume operators for cooking delicious flame broiled hamburgers, chicken, wings and steak sandwiches. Infrared burners cook quickly and thoroughly, offering a better tasting product and sealed-in juices. Cooks up to 350 frozen, 4 oz. patties per hour.

FEATURES

- Return-flow Operation
- Single Meat Chain
- 600 Degree F Operating Temperature
- Automatic Temperature Control
- Integrated Bun Toaster
- Heavy gauge stainless steel welded frame construction
- 4 Infrared burners for thorough cooking
- Medium Capacity
- 99% smoke-free with optional catalyst
- Easy Cleaning and Maintenance
- Single Pilot Ignition
- Side Burner Access Panel

BENEFITS

- Consistency
- Versatility
- Speed
- Quality
- Flexibility
- Food Safety
- Labor Savings
- Gas/Energy Efficient

APPROVALS

- UL Listed
- NSF/ANSI 4

ADD-ON COMPONENTS

Extended Meat Chain

Labor Savings

Extended Bun Chain

Labor Savings

Flat Table

Maximize storage space underneath

Tubular Stand

Ease of cleaning

Catalytic Converter

Eliminated 99% of smoke
Reduces gas cost by over 25%
Helps "cool down" the kitchen

Catalyst Hood Kit

Facilitates the installation of the Catalytic Converter in the field.

OPTIONAL PARTS

220 Volt Female Receptacle

Necessary for use with a Bun Platen unit

48" Gas Hose

Eliminates gas leaks

3/4" Brass Quick Disconnect

Facilitates easy disconnect for cleaning

Cable Restraining Device

Safety- relieves strain on gas hose

Emergency Spare Parts Kit

Facilitates easy repairs, reducing down-time



CHAR-MASTER™ Universal Flame Broiler

MODEL 7450 Return-flow

DIMENSIONS	INCH	MM
Length	33-1/2	850
Height	31-1/2	800
Width	37	940

WEIGHT	LB	KG
Shipping	515	234

EXHAUST	CFM	CMH
Typical	600	1020

ENERGY — GAS MODELS

Gas connection 3/4" N.P.T.

Electrical connection (specify exact voltage)

Domestic 120V IØ 50/60Hz 18A

Export 200-240V IØ 50/60Hz 18A

Natural Gas 3" W.C.

BTU/hr 38,000

kW 14.6

Liquid Propane 8" W.C.

BTU/hr 39,000

kW 15.2



750 Beta Drive, Unit "G"
Cleveland, Ohio 44143
800-272-8546
440-460-3990
Fax: 440-460-3999
Email: info@BPSproductsinc.com

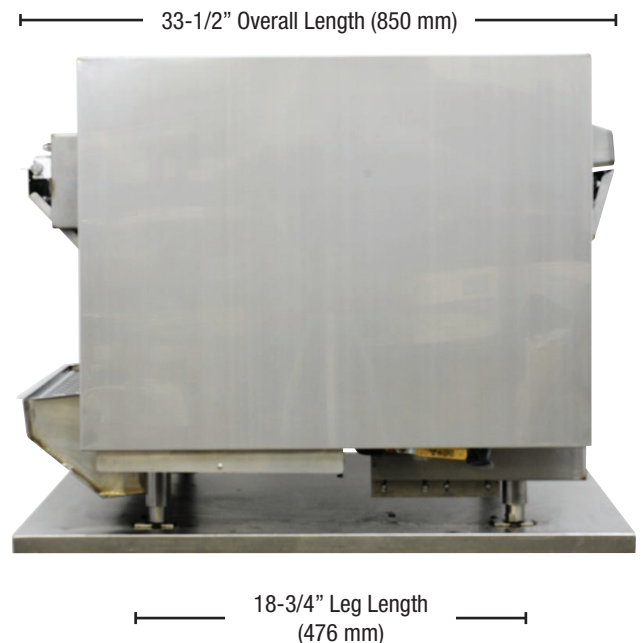
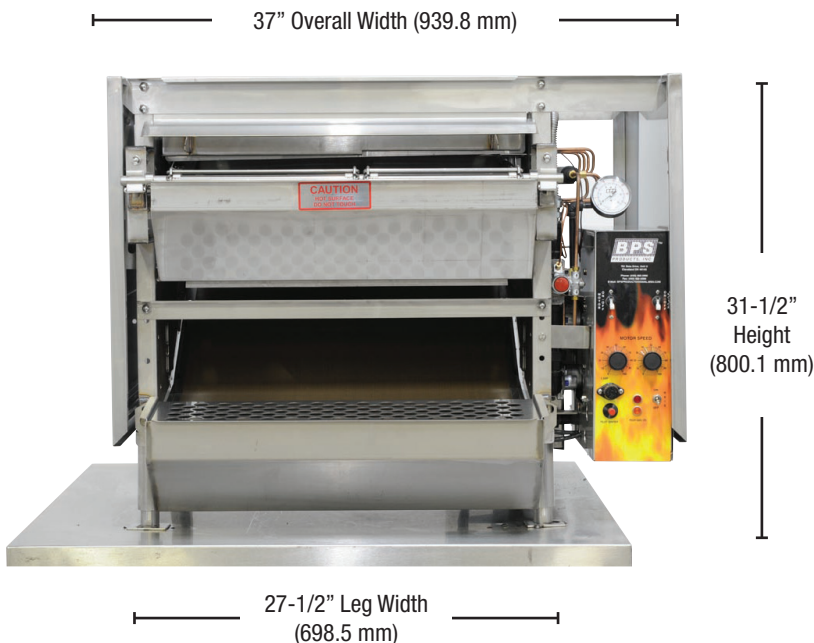

Metric dimensions rounded up to the nearest whole millimeter. Specifications subject to change without notice.